

## Differential Pressure Switch General Instructions

### Application

For low or line voltage control of static, velocity or total pressures, or differential static or total pressures of air and non-combustible gases only.

### Specifications

#### Setpoint:

**Factory Set,** 0.07" (1.8 mm) W.C.

**Field Adjustable,** 0.07 to 1" (1.8 to 25.4 mm) W.C.

**Sensing Element:** Neoprene diaphragm.

**Differential:** 0.04" (1 mm) W.C. at minimum setpoint to 0.1" (3 mm) W.C. at maximum setpoint.

#### Environment:

##### Ambient Temperature Limits,

**Shipping,** -40 to 140°F (-40 to 60°C).

**Operating,** 35 to 140°F (0 to 60°C).

**Humidity,** 5 to 95% R.H., non-condensing.

**Locations,** NEMA Type 1 indoor only.

**Maximum Pressure:** 12" (305 mm) W.C.

**Electrical Switch:** Snap action SPDT.

**Ratings,** See Table-1.

**Connections,** Code screw terminals

**Case:** All metal with 1/2" conduit opening.

**Mounting:** In vertical position on any surface free of vibration.

**Dimensions:** 5-1/8" high x 4-3/4" wide x 4-3/8" deep (130 mm x 121 mm x 111 mm).

#### Accessories

AP-302	Static probe for turbulent air
AP-305	Static probe for low actuating pressure
AT-208	Duct mtg. kit for remote probes other than AP-302 or AP-305

### Pre-Installation

### Inspection

Visually inspect the carton for damage. If damaged, notify the appropriate carrier immediately. Visually inspect the device for obvious damage due to shipping. Return damaged parts to place of purchase.

### Required Installation Items

- Wiring or piping diagrams
- Appropriate screwdrivers (not provided) for mounting screws (provided)
- Conduit fittings (not provided)

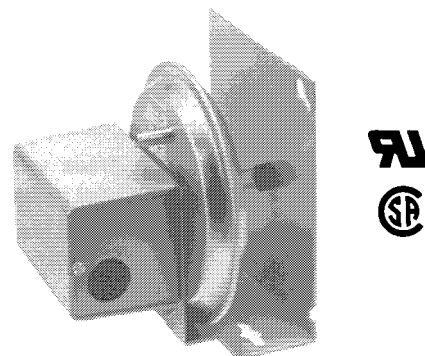

### Installation

#### Caution:

1. Installer must be a qualified, experienced technician.
2. Disconnect power supply before installation to prevent electrical shock.
3. Make all connections in accordance with the wiring diagram, and in accordance with national and local electrical codes. Use copper conductors only.
4. Avoid locations where excessive moisture, corrosive fumes or vibrations are present. NEMA 1 devices are intended for indoor use primarily to provide a degree of protection against contact with the enclosed equipment.
5. For use with air or non-combustible gases only.

**Table-1 Maximum Electrical Switch Ratings**

Vac	Full Load Amps	Locked Rotor Amps	Pilot Duty (VA)	Non-Inductive Amps
24V	--	--	60	--
120V	6.25	37.5	300	--
240V	3.1	18.6	300	--
277V	2.7	16.2	300	10



Figure-1 Direct Mounting of Probe and Dimensions.

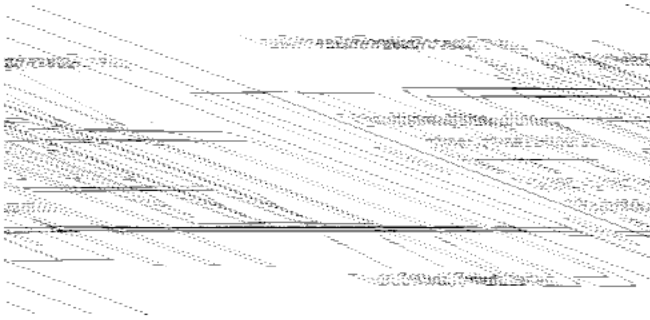

Figure-2 Remote Mounting of Probes.

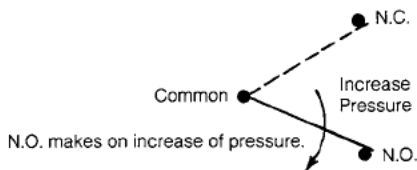

Figure-3 Switch Action and Terminal Identification.

## Mounting

1. Select direct or remote mounting. For field mounting use mounting bracket as a template. For factory mounting use dimensions provided. See Figures-1 and 2.
2. Select appropriate probes from Tables-2 and 3.  
**Probes:** Probes can be constructed from 1/4" O.D. copper, brass, or aluminum tubing. The ends of the probes should be cut square to the sides of the tube and deburred. Total pressure probe must have the sensing end bent at 90°, approximately 1" to 3" (25 mm to 76 mm), from the tip. Use AT-208 kit to mount probe to duct. Use AP-302 static probe in areas with air turbulence caused by filters, dampers, etc. Not included. Use AP-305 static probe where there is very low actuating pressure.
3. Install probe. See Figure 4. Sampling probes should be located in areas of minimum air turbulence (6 to 8 duct diameters downstream from fan outlet, elbows, tees, or dampers). If this is not possible, locate the probe tip as close to the center of the duct as possible.



Figure-4 Sample Probe Identification.

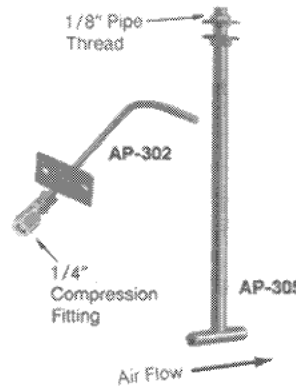

AP-302 static probe is used in areas with air turbulence caused by filters, dampers, etc. at velocities up to 12,000 fpm (3658 mpm).

AP-305 static probe is used where there is a very low actuating pressure.

Figure-5 Optional Probes.

4. Mount the PC-301.

**Note:** The diaphragm must be mounted in a vertical plane and in a location free from vibration.

5. Connect the remote probe(s), if any, to the PC-301.

6. Make all connections in accordance with job wiring diagrams and in compliance with national and local codes. On an increase of air pressure to above setpoint, common contact of switch is made to normally open contact. On a decrease of air pressure to below setpoint, common contact of switch is made to normally closed contact.

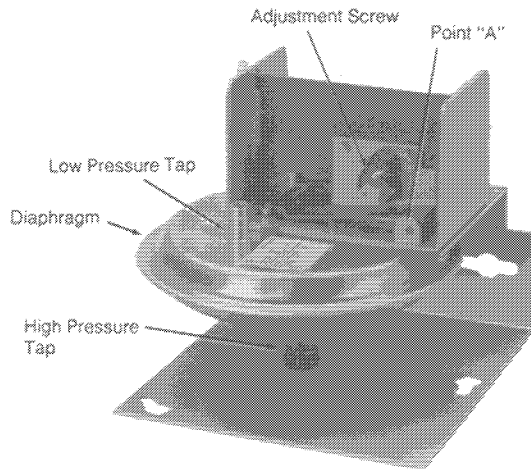

Figure-6 Part Identification.

## Adjustment

To increase setpoint, turn adjustment screw clockwise. Adjustable 0.07"  $\pm$ 0.02" to 1.0" (1.78 mm  $\pm$ 0.5 mm to 25 mm) W.C. To decrease setpoint, turn adjustment screw counterclockwise.

---

**Note:** Units are shipped at minimum setpoint.

---

If readjustment to minimum setpoint is required, proceed as follows without any air pressure applied to diaphragm.

1. Turn adjustment screw full CCW.
2. Push on spring at point A (Figure 6) and maintain pressure during steps 3 and 4.
3. Turn adjustment screw CW until common contact is made to normally open contact.
4. Turn adjustment screw CCW until common is made to normally closed contact. Then turn adjustment screw 1/8 turn more CCW.

**Table-2 Direct Mount of One Probe.**

	Static	Velocity	Total	$\Delta$ Static	$\Delta$ Total
High Pres. Tap*	Probe 1	Probe 2	Probe 2	Probe 1	Probe 2
Low Pres. Tap	--	Probe 3 Remote	--	Probe 3 Remote	Probe 4 Remote

**Table-3 Remote Mounting of Probe(s).**

	Static	Velocity**	Total	$\Delta$ Static	$\Delta$ Total
High Pres. Tap*	Probe 3	Probe 4	Probe 4	Probe 3	Probe 4
Low Pres. Tap	--	Probe 3	--	Probe 3	Probe 4

\* Highest (absolute) pressure should be applied to high pressure tap.

\*\*Pilot can be used instead of two probes

$\Delta$  = Differential

On October 1st, 2009, TAC became the Buildings business of its parent company Schneider Electric. This document reflects the visual identity of Schneider Electric, however there remains references to TAC as a corporate brand in the body copy. As each document is updated, the body copy will be changed to reflect appropriate corporate brand changes.

---

Copyright 2010, Schneider Electric  
All brand names, trademarks and registered  
trademarks are the property of their respective  
owners. Information contained within this  
document is subject to change without notice.

F-16160-9

